

10-Year Limited Tank/ 10-Year Limited Parts Warranty*

Hybrid Electric heat pump water heaters from American are the most versatile, energy-efficient option for the consumer who is looking to go green, providing the same amount of hot water as a conventional electric water heater at half the cost.

How Do They Work?

- Absorb ambient heat from the surrounding air to heat water using a compressor and “Environmentally-Friendly” R134a refrigerant
 - Self-contained heat pump unit is integrated into the top of the tank
 - Multiple operating modes maximize efficiency and meet increasing hot water demands

ELIGIBLE FOR FEDERAL TAX CREDIT

- Visit www.americanwaterheater.com for more information

FEATURES

Increased Storage

- High capacity storage tank enables the heat pump to operate more frequently than the heating elements. This provides higher energy efficiency and lower operating costs saving money for the homeowner.
- High capacity storage tank provides more hot water for peak demand periods

Energy-Efficiency

- Up to a 2.4 Energy Factor (EF) rating conserves energy and meets ENERGY STAR® qualifications

Choice of Operating Modes

- Select from Efficiency, Hybrid, or conventional Electric modes to match heating requirements to environmental conditions. Hybrid mode automatically adjusts between compressor and element, depending upon heat requirements. Vacation mode reduces operating costs and provides freeze protection during extended absence.

Backup Electric Elements

- Long-lasting incoloy heating elements, 240V/2000W lower and 240V/4500W upper, helps heat water when in conventional Electric or Hybrid modes

Electronic User Interface

- User-friendly LCD Touch Pad control with plain English text and intuitive status icons provides easy interaction
- Large LCD temperature display (see back) shows temperature in °F or °C
- 3 line 13 character backlit LCD display communicates current set point, status and operational information
- Advanced diagnostics convey error messages in plain English. The last four error messages are saved in the control system memory.
- Child resistant safety lock deters unwanted access to temperature settings

Powered Anode

- A non-sacrificial powered anode protects the tank from corrosion and eliminates the service requirements of conventional anode rods.

Dehumidification

- Ideal for basements or garage installations; the compressor transfers heat to the water while dehumidifying and cooling the ambient air.
- Washable air filter is easily removed for routine cleaning

Dry Fire Protection

- Control system checks to ensure the tank is full of water during start up to prevent dry firing the heating elements



HPE6280H045DV
Model Shown



*For complete warranty information consult the written warranty of American Water Heaters found at www.americanwaterheater.com, or call (800) 456-9805.



Residential Hybrid Electric Heat Pumps



ELECTRONIC USER INTERFACE

- Large LCD touch pad display
- Intuitive icons clearly indicate the current operation mode
- Individual backlit buttons for mode selection:
 - Efficiency
 - Hybrid
 - Electric
 - Vacation
- Three-line display communicates current status and displays error messages in plain English when applicable
- Safety lock

EFFICIENCY MODE

- Utilizes the heat pump for all water heating
- Automatically reverts to heating element if ambient air or water temperatures are outside optimal operating range for heat pump

HYBRID MODE

- Utilizes the heat pump or heating element, depending on demand

ELECTRIC MODE

- Standard electric water heater operation

VACATION MODE

- One touch operation maintains tank temperature of 60° F (15.6° C) during vacation or extended absence to reduce operating costs and provide freeze protection

MODEL	GALLON CAPACITY	ENERGY FACTOR BY MODE			1ST HOUR RATING BY MODE			HEIGHT (Inches)	DIAMETER (Inches)	HEIGHT TO WATER OUTLET (Inches)	HEIGHT TO DRAIN VALVE (Inches)	HEIGHT TO T&P (Inches)	Approximate Shipping Weight (LBS)
		EFFICIENCY	HYBRID	ELECTRIC	EFFICIENCY	HYBRID	ELECTRIC	A	B	C	D	E	
HPE10260H045DV	60	2.40	2.33	0.88	51	68	66	67-1/3	24-1/2	41	4-1/4	40	332
HPE10280H045DV	80	2.30	2.33	0.85	70	84	76	81-1/2	24-1/2	55	4-1/4	56-1/3	410

Other Features:

- Powered anode to protect against tank corrosion (Max 50 mA draw)
- 2 Inch "Environmentally-Friendly" non-CFC foam insulation reduces standby heat loss
- Coefficient of performance (COP) 3.1
- Child resistant brass drain valve
- CSA certified and ASME rated T&P relief valve
- Water temperature set point range; 95°F to 150°F (35°C to 66°C)

Operating Requirements:

- Requires provision for condensate draining; if a suitable drain is not available a condensate pump is required
- Recommended minimum 750 cubic feet of space for air circulation heat exchange
- 240 VAC single phase power supply with 25 amp circuit breaker

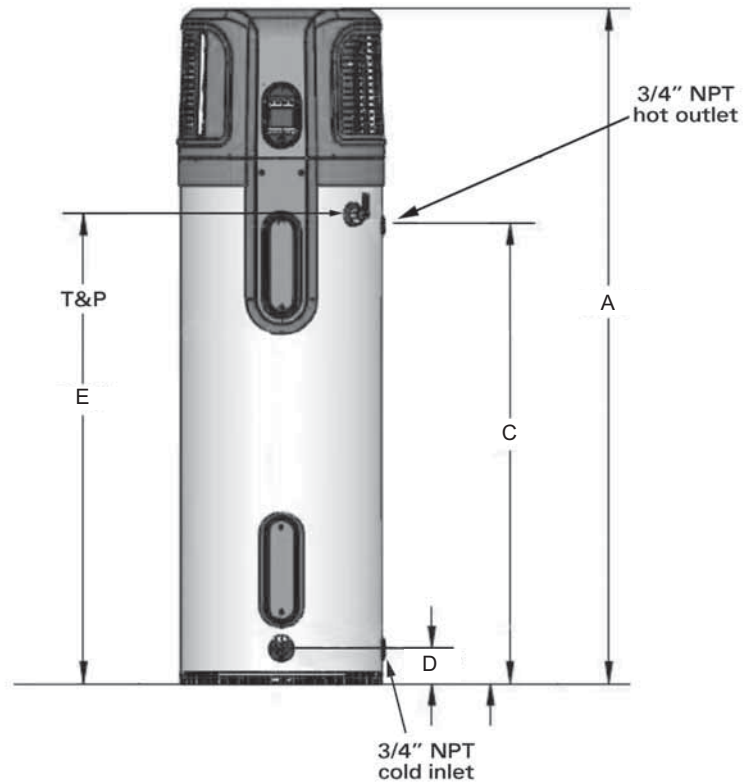

Distributed By:

Order Entry and Sales

500 Princeton Road (FEDEX, UPS)
 Johnson City, TN 37601-2030
 P.O. Box 4808 (Mailing)
 Johnson City, TN 37602-4808
 (800) 937-1037
 FAX (800) 581-7224

Warranty and Service

500 Princeton Road (FEDEX, UPS)
 Johnson City, TN 37601-2030
 P.O. Box 1597 (Mailing)
 Johnson City, TN 37605-1597
 (800) 456-9805
 FAX (800) 999-5210